

Encore

A piece for voices

Performance Notes

1. The piece is suitable for five or more voices. It is especially appropriate as a concert encore.
2. Singers should be arranged in a single row as a crescent facing the audience. The first person to sing is on the left hand end of the row as viewed by the audience.
3. Before starting the piece each singer must decide upon a note they are going to use for the piece. They must use precisely this pitch for the whole piece - except in the penultimate bar where they must sing the note one octave higher. It is intended that singer's individual notes will clash with those chosen (independently) by their immediate neighbours.
4. The first note is sung by the person on the far left (as viewed from the audience) side of the ensemble (ie the one at the start of the row).
5. Each successive sung note is to be sung by the next person. The next person is defined as the person on the immediate left hand side of the current person. When the sequence reaches the end of the row the next person to sing is the one at the start of the row. In this way the audience will hear the sound sweeping from left to right - very slowly at first and then more rapidly as the number of vocalists overlapping increases. Eventually everyone is singing chaotically simultaneously.
6. The piece is to be sung without adhering to a particular rhythmic tempo. However each crotchet length is approximately $\frac{1}{2}$ second but will vary for each crotchet throughout the piece.
7. There is a steady crescendo throughout the piece.
8. The subtle change in pronunciation between "ON" and "EN" must only become apparent to the audience in the penultimate bar.

Roger Swann – 1999

Photocopying and Performance

Photocopying of the music is authorised by the composer provided both the performance notes and the notation page are both reproduced in full (including this notice) and without alteration. The composer does not require or expect remuneration for any performance. Please e-mail encore@cigol.com details of date, venue, event and approximate audience size for any performance.

Photocopying of the music is authorised by the composer provided both performance notes and the notation page are both reproduced in full (including this notice) and without alteration. The composer does not require or expect remuneration for any performance. Please e-mail details of date, venue, event and approximate audience size to encore@cigol.com for any performance

Encore - A Piece For Voices

(Please refer also to performance notes)

Roger Swann - 1999

 = approx. 120

rep. ad. lib.

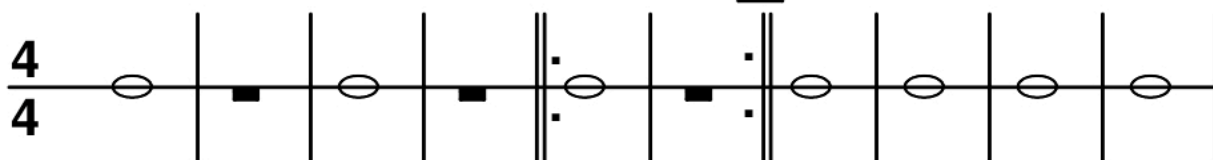

ON

ON

ON

ON

ON

ON

ON

mp

still mp

gradual crescendo

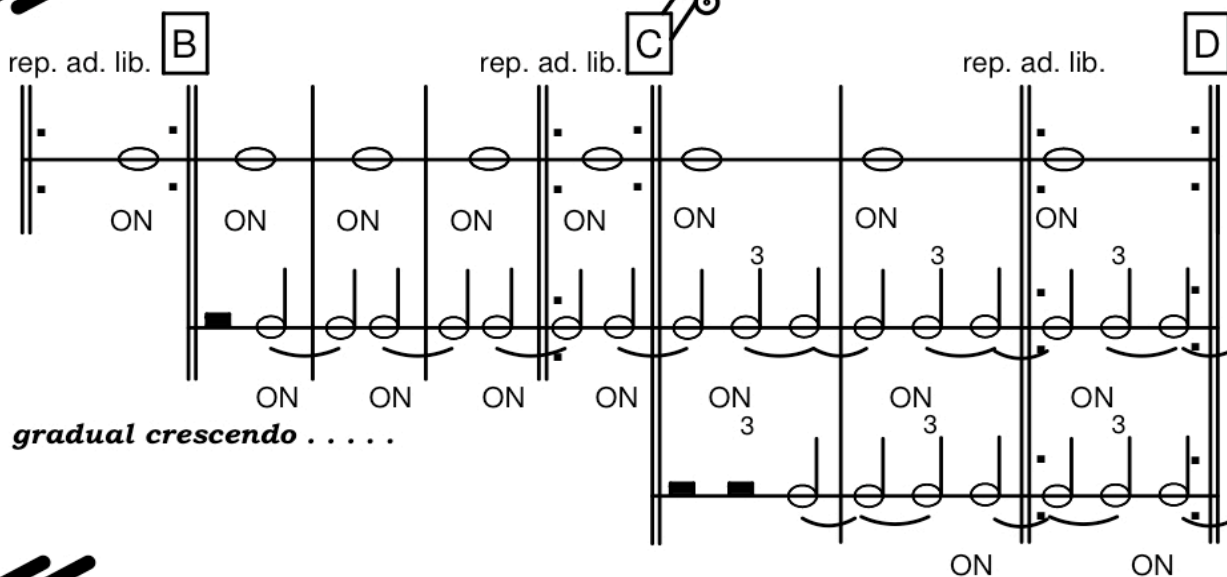
gradual crescendo

rep. ad. lib.

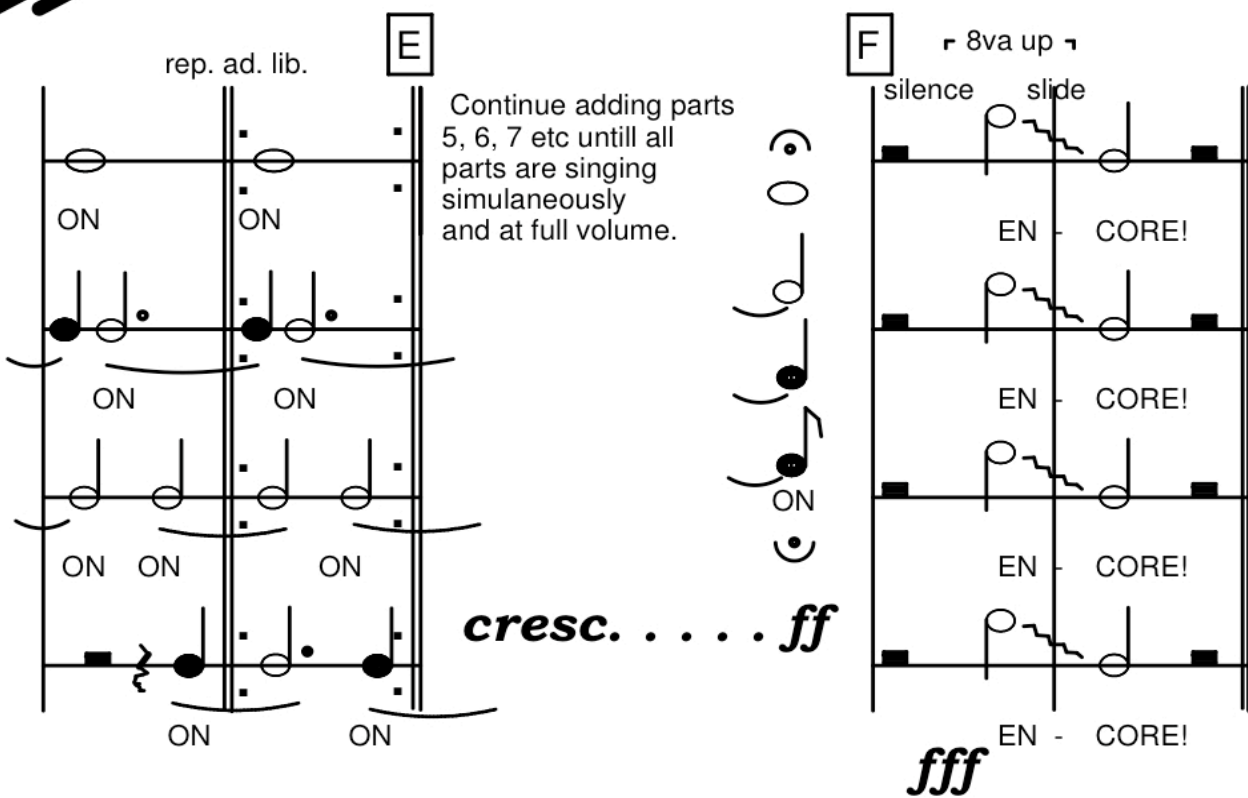
E

Continue adding parts
5, 6, 7 etc until all
parts are singing
simultaneously
and at full volume.

cresc. ff

F

8va up

silence slide

EN - CORE!

EN - CORE!

EN - CORE!

EN - CORE!

fff